

14 Nawiewniki ścienne

Fresh TL-80R

A B C D E F H

TL80R



TL80R-dB



TL80R	
Lp.	
1	regulator nawiewu TL80R
2	przeście ścienne Ø81/85 x 75mm
3	adapter 8 roz. Ø81/85 x 75mm
3	kratka zewnętrzna #150

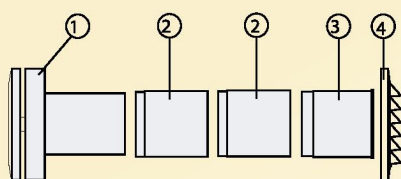

TL80R-dB	
Lp.	
1	regulator nawiewu TL80R
2	pokrywa #180 mm
3	rura tłumiąca dB Ø81/140 x 400mm
4	pokrywa #180 mm
5	adapter 8 Ø81 x 30mm
6	kratka zewnętrzna #150 mm

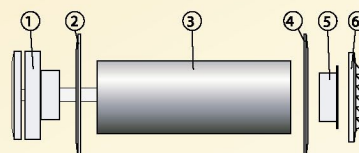

Tłumienie hałasu dla Fresh TL-80R dla L=400

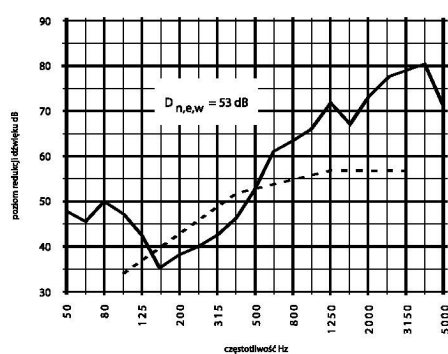

ochrona kondensacyjna

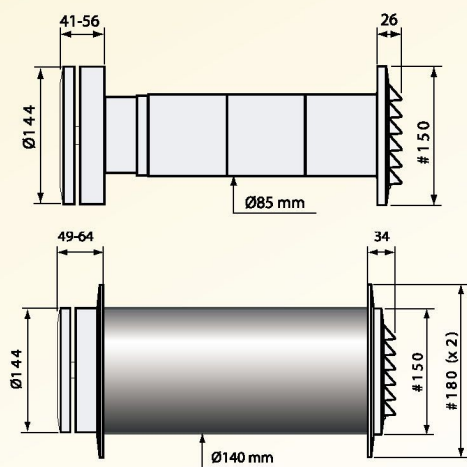
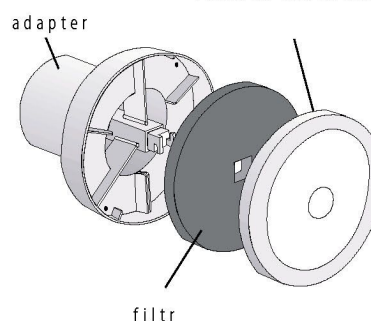

Wydajność TL80R

